



SeaPal Waterproof Case
Instruction manual

Congratulations on purchasing your JOBY SeaPal Waterproof Case. The JOBY SeaPal opens new possibilities to advance your phone photography and videography. You can also share the images you've captured with friends and family via social media, iMessage, SMS and livestream.

Please read the following instructions and care tips before using your JOBY SeaPal for the first time.

What's in the box

- JOBY SeaPal Waterproof Case
- Silicone O-Ring Grease
- Wrist Laynard
- Bumper Set

Table of Contents

- [Whats in the box](#)
- [Nomenclature](#)
- [Initial setup](#)
- [Using the JOBY SeaPal underwater](#)
- [Safety information](#)
- [Maintenance](#)
- [Limit of liability](#)
- [Warranty](#)
- [Servicing](#)

Nomenclature



Initial Setup

- Before using your JOBY SeaPal for the first time you must conduct a water test without the phone as explained below. You can perform the water test in any body of water that allows submersion down to depths of 1-3ft (30-90cm). Make sure the O-Rings are clean and dry before testing. If the O-Rings or the JOBY SeaPal show any signs of damage do not use.
- Attach the included JOBY SeaPal Wrist Lanyard by tying the tether to the leash attachment point.
- Close the backplate and lock the side latch. An audible 'click' should be heard to indicate the latch is locked.
- Conduct a visual inspection of the JOBY SeaPal to be sure a good seal has been created by checking that the entire backplate has engaged well with the front section, and there is no debris or other material interfering with the sealing O-Ring. A small gap between the backplate and frame is normal.
- Always use a wrist lanyard or leash when using the JOBY SeaPal in any body of water as it is negatively buoyant, therefore if it is dropped, it will sink.
- Once the JOBY SeaPal Wrist Lanyard is attached to your wrist you can immerse your JOBY SeaPal into the water.
- Hold the JOBY SeaPal and immerse it into the water for a period of 20 seconds to ensure it is watertight.
- Remove the JOBY SeaPal from the water, dry with a towel and check that no water has penetrated inside. Point the JOBY SeaPal up and check around the backplate edges, then point it down and check the edges of the front port



JOBY SeaPal
Wrist Lanyard
attachment point



Turn the latch
clock-wise to
lock

for any water that may have penetrated. Water can enter the JOBY SeaPal when opening the backplate, so do not confuse this with a leak.

- If this is all clear and there has been no ingress, repeat Step 1 and hold the JOBY SeaPal under the water for 30 seconds.
- Repeat Step 2, and if no water has entered you are ready to install your phone and begin shooting. Dry the case completely and open the latch following the picture on the right.
- If any water enters the JOBY SeaPal during the test, dry it out completely and then repeat the instructions on installing your port and water testing.



Installing your phone

Make sure the inside of your JOBY SeaPal is completely dry and clean. Clean the phone screen of any fingerprints or debris. Remove the phone case from the phone if any. Insert the phone into the rubber bumpers inside the JOBY SeaPal using the bumper layout for your phone. These are located starting on the next page.

The home screen should face upwards so you can see your screen through the transparent membrane.

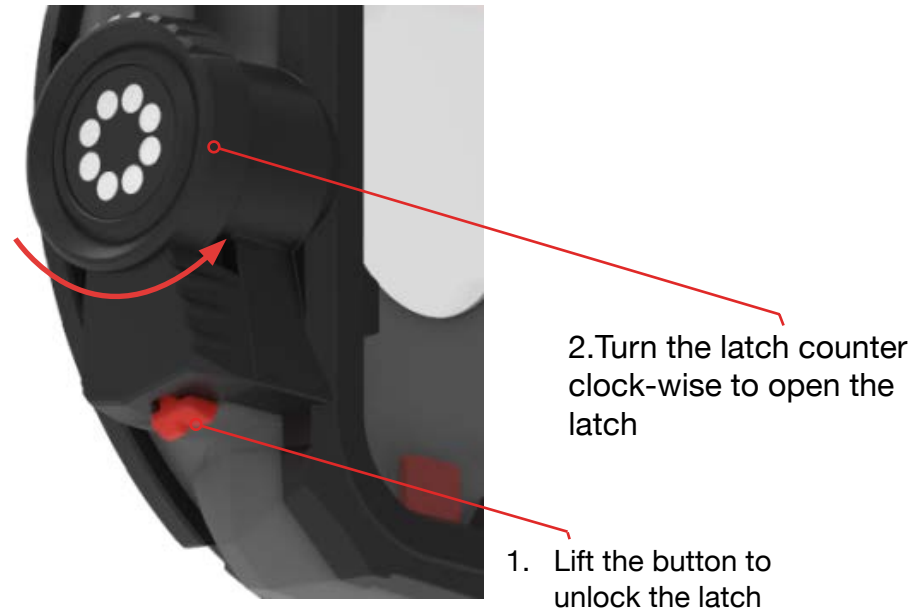
Before closing the backplate, make sure the main O-Ring is free from any sand or other debris. Close the backplate and lock the side handle latch. Take care that your leash does not interfere with the hinge or O-Ring when closing the backplate. Now your JOBY SeaPal is ready for the water, snow, dirt or

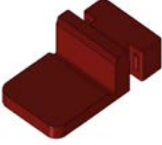
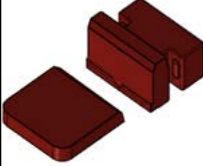

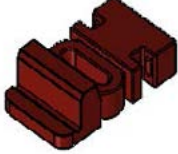
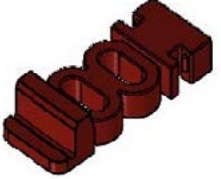
		A	B	C	D	E
Bumper configuration	Phones					
1	Apple iPhone 15 Pro Max Apple iPhone 15 Plus Apple iPhone 14 Pro Max Apple iPhone 14 Plus Apple iPhone 13 Pro Max Apple iPhone 12 Pro Max	8	0	0	0	0
2	Apple iPhone 15 Pro Apple iPhone 15 Apple iPhone 14 Pro Apple iPhone 14 Apple iPhone 13 Pro Apple iPhone 13 Apple iPhone 12 Pro Apple iPhone 12 Samsung S22 Samsung S23	4	0	0	2	2
3	Samsung S22+ Samsung S23+	7	0	0	0	0
4	Samsung S22 Ultra Samsung S23 Ultra	0	8	4	0	0

Bumper Layout 1

- Apple iPhone 15 Pro Max
- Apple iPhone 15 Plus
- Apple iPhone 14 Pro Max
- Apple iPhone 14 Plus
- Apple iPhone 13 Pro Max
- Apple iPhone 12 Pro Max

8X

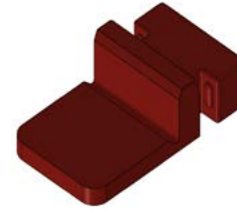

A

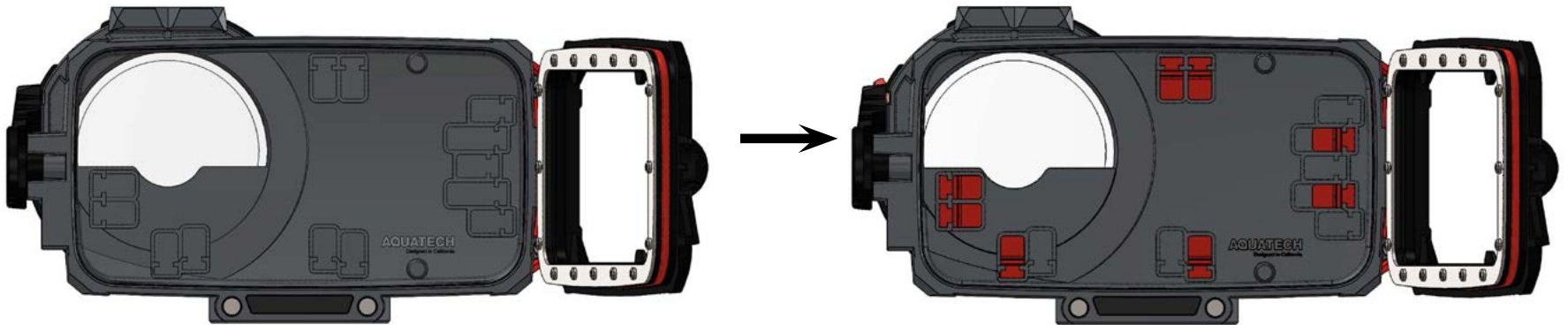

Install the included bumpers based on the bumper layout above.

NOTE: When using the iPhone 15 Plus and Pro Max in your JOBY SeaPal make sure to clamp the backplate and front together tightly. This will minimize the phone movement within the case while in use.

Bumper Layout 2

- Apple iPhone 15 Pro
- Apple iPhone 15
- Apple iPhone 14 Pro
- Apple iPhone 14
- Apple iPhone 13 Pro
- Apple iPhone 13
- Apple iPhone 12 Pro
- Apple iPhone 12
- Samsung S22
- Samsung S23

8X

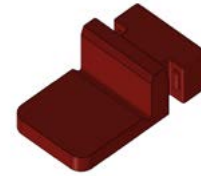

A

2X

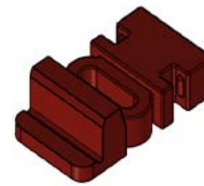

D

2X

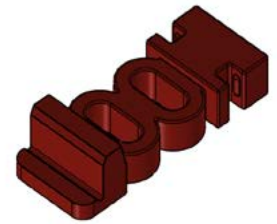

E

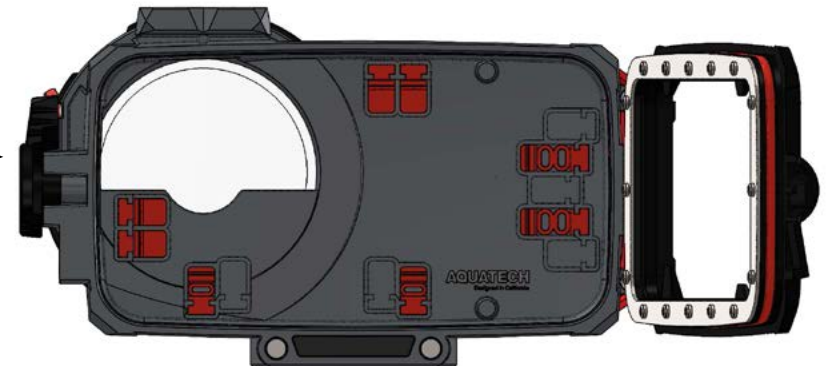
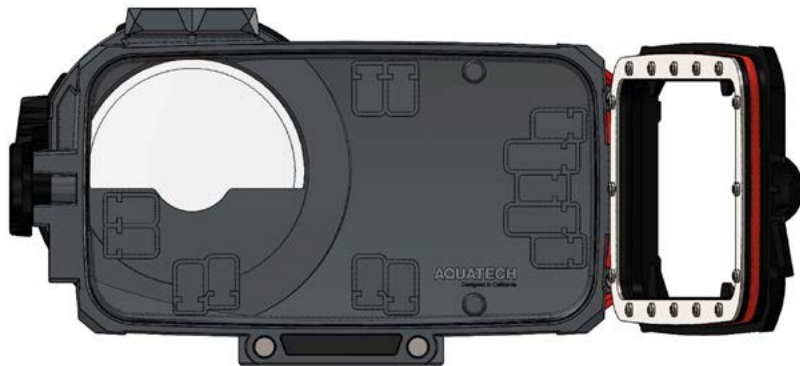

Install the included bumpers based on the bumper layout above.

Bumper Layout 3

- Samsung S23+
- Samsung S22+

7X



A

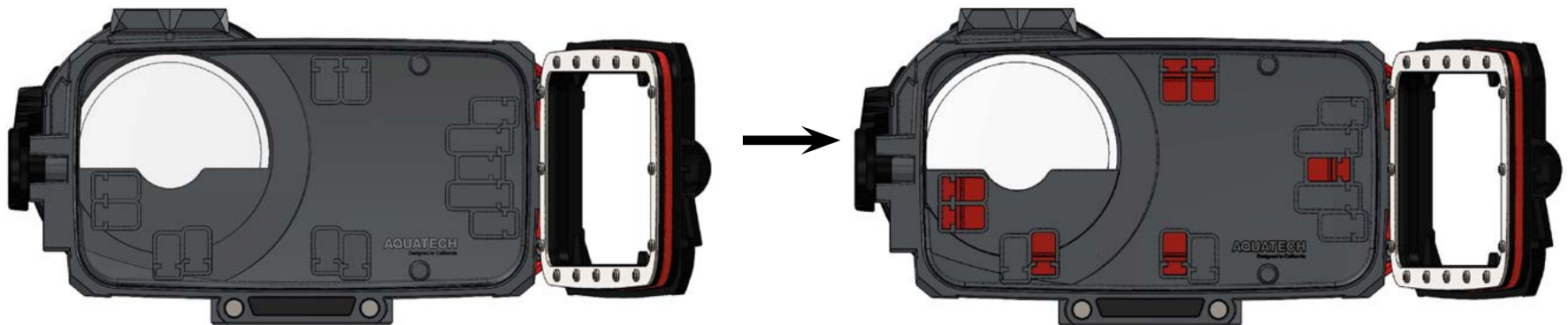

Install the included bumpers based on the bumper layout above.

Bumper Layout 4

- Samsung S23 Ultra
- Samsung S22 Ultra

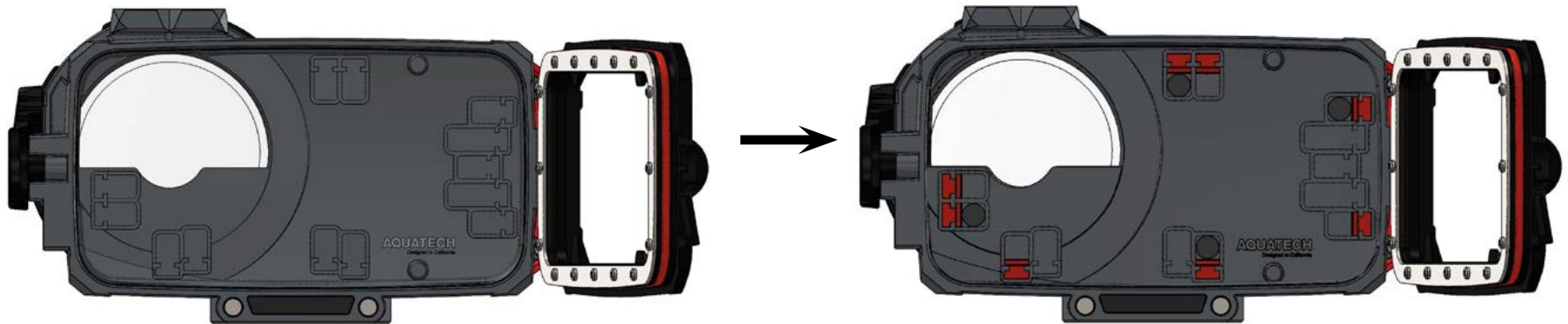
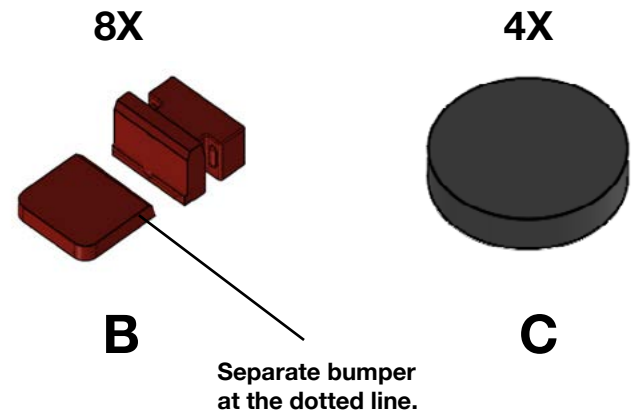

Install the included bumpers based on the bumper layout above.

anywhere else you can take it!

NOTE: It is recommended any screen protectors be removed before using the JOBY SeaPal. The screen protectors reduce touch sensitivity through the rear membrane and can make controlling the phone difficult.

Venting your JOBY SeaPal

‘Venting’ is a technique of expelling air from the JOBY SeaPal before closing the backplate. To ‘vent’ your JOBY SeaPal, apply pressure to the rear membrane as you close the rear backplate and lock the side handle. Pushing onto the phone with 1 finger will remove a small amount of air, or using your whole palm will remove a greater amount of air. Each action will have different pros and cons as sensitivity and water interference will vary through the techniques. A unit that is not vented will be slightly less sensitive when controlling the touchscreen and more resistant to water interference. A fully vented unit will be much easier to control and navigate the touch screen, but will be more likely to receive water interference. Experimenting with these techniques will allow you to see which technique suits you and your application best.

Using the JOBY SeaPal underwater

Your phone uses a capacitive touch screen which will not function the same underwater as it will above. Functionality loss will occur to the touchscreen when the JOBY SeaPal is used underwater. Before going underwater make sure that your camera app is open. When staying below the surface for extended periods (ie: diving) follow the below tips:

- Set the phones ‘Auto-Lock’ to never.
- Settings>Display & Brightness>Auto Lock

- Turn ‘Airplane Mode’ on.
- Keep the camera app open before you submerge
- Select your preferred capture method first
- (ie: photo or video etc.)
- All settings can be changed as soon as you resurface with your JOBY SeaPal.

Using your camera

Your JOBY SeaPal allows full control over the phone camera App. When you have launched the app it is easy to swipe through capture modes, swap between front and rear cameras, review pictures.

Placing your phone in ‘Airplane Mode’ will prevent photo or video capture being interrupted by calls or notifications. To lock focus and exposure of a subject, press and hold the touchscreen on the desired subject.

Touchscreen

The JOBY SeaPal rear membrane allows you full access to your phone touchscreen. Making capturing images and sharing them a seamless experience, while protecting your phone’s delicate touchscreen. The new rear membrane material provides a more responsive and intuitive experience while navigating your touchscreen.

Safety information

- Do not exceed depths of 10m/33ft.
- Do not exceed depths of 90cm/3ft without a phone

installed in the SeaPal.

- Always use your SeaPal with a leash or the provided Wrist Lanyard.
- Never store your SeaPal in direct sunlight or environments exceeding temperatures of 30°C/86°F.
- Do not store your phone inside the SeaPal in direct sunlight.
- The included Wrist Lanyard is intended only for calm water use. The 'SeaPal Sports Leash' (sold separately) should be used in the surf or any turbulent water.
- Contains small parts which may be a choking hazard. Not suitable for children under 3 years of age
- **WARNING:** Practice extreme caution when diving into water, swimming in surf or other dynamic outdoor pursuits. Only use this product in settings that are within yours or other's capabilities. Serious injuries or drowning could occur if you are not a competent swimmer for the prevailing conditions

Maintenance

- After each use, remove your phone before again closing the SeaPal and rinsing it thoroughly in fresh water.
- Rinse the latch mechanism and spring thoroughly after each use to ensure it retains full operation.
- Dry your SeaPal before storing.

- Store in a cool, dry area.
- Use the provided grease periodically on the O-Rings to reduce friction and increase operating life. Only a small amount of grease should be applied each time

Warranty info, limit of liability

Thank you for purchasing a JOBY product.

JOBY products are warranted to be fit for the purpose for which they have been designed, and to be free from defects in materials and workmanship.

This guarantee does not cover the product against subsequent damage or misuse. As JOBY SeaPal products are often used in extreme and volatile environments, we are unable to cover for loss or damage of equipment. Loss of income, reputation or other financial expenses, such as personal injury are also not covered by this warranty.

The period of validity of the Standard Limited Warranty is defined by the law in force in the country, state or region where the product is sold. Please retain your receipt as proof of purchase.

How to get service?

After sales service:

www.joby.com

Videndum Media Solutions Spa

Via Valsugana 100 - 36022 Cassola (VI) - Italy

© 2023 Videndum Media Solutions Spa

JOBY is a registered trademark of Videndum Media Solutions Spa